

# Coaxial switches, N-type

## Medium power model PM 7535

This coaxial switch uses blade type contacts for high switching speed and long operational life. The contact blades are integrated in a coaxial structure to assure perfect match over a large frequency range. The solenoids have separate connections which can be used to arrange for different break-make time diagrams. When the solenoids are shunt-connected the contacts will operate in a break-before-make mode.

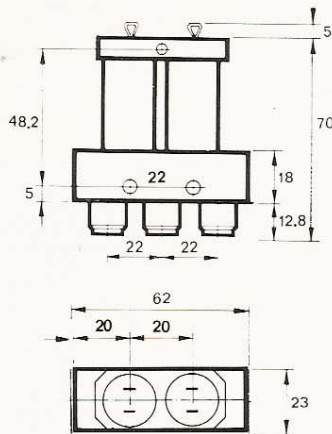

PM 7535

## High power model PM 7540

The high power coaxial SPDT PM 7540 has a design with excellent thermal conduction between the centre conductor and housing to enable high power operation. This is achieved by using special thermoconductive materials as dielectric.

The actuator is failsafe and the RF-contacts operate in a break-before-make model.

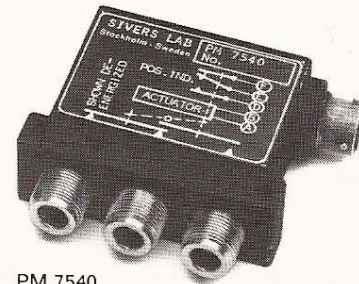
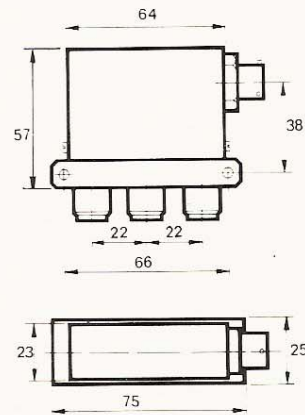

PM 7540

### Specification, both models, DC-12.4 GHz

Frequency	DC-1 GHz	1—7 GHz	7—12.4 GHz
VSWR	<1.10	<1.35	<1.50
Insertion loss	<0.2	<0.3	<0.5
Isolation	>70	>65	>60

RF impedance: 50  $\Omega$

Max. RF power:<sup>1)</sup> PM 7535 peak 10 kW,<sup>2)</sup>  
average 50 W at 12.4 GHz  
PM 7540 peak 10 kW,<sup>2)</sup>  
average 1 kW at 1 GHz  
300 W at 10 GHz

See also diagram, page 24.

<sup>1)</sup> under steady-state condition, switching RF power will damage the components

<sup>2)</sup> at +25°C, 0.1 MPa (sea level).

<sup>3)</sup> at +25°C, nominal voltage.

Model	PM 7535	PM 7540
Switch. function	SPDT	SPDT
Actuator	failsafe	failsafe
Switching time	25 ms	100 ms
Pull-in/holding current <sup>3)</sup>	200/200 mA	220/220 mA
Position indicator	no	yes
Terminals	solder pins	connectors PT07-10-6P
Weight	250 g	350 g
Actuator voltage	28 $\pm$ 3 V DC	28 $\pm$ 2 V DC

Temperature: —55°C to +85°C ambient

RF connectors: N-type jack per MIL-3912

Life: min. 10<sup>6</sup> actuations guaranteed

Material: RF-connectors stainless steel  
RF-circuit: aluminium (chromated)  
beryllium copper, gold plated

Finish: dull black paint, epoxy

Vibration: (PM 7540) sine 5—40 Hz,  
amplitude 1.5 mm  
sine 40—2000 Hz,  
acceleration 10 g  
(PM 7535) sine 20—60 Hz,  
amplitude 0.35 mm  
sine 60—2000 Hz,  
acceleration 5 g